

PHOENIX

Composting Toilet



Odorless • Waterless
Rugged • Capacious
Owner-Friendly

Residential Models



195 Meadows Road
Whitefish, MT 59937
Voice: 406-862-3854
Fax: 406-862-3855
phoenix@compostingtoilet.com
<http://www.compostingtoilet.com>

Benefits of the Phoenix

Odorless. There are *no* unpleasant smells in the toilet room, tank area, or around the building. Aerobic decomposition and a positive ventilation system ensure odorless operation. Finished compost is inoffensive.

Waterless. Designed for dry operation. Saves thousands of gallons of water per person.

Rugged. *Lasts a lifetime!* Thick, tough, insulated walls of crosslinked polyethylene. Corrosion resistant fittings.

Capacious. Accommodates families, guests, relatives. Large surge capacity.

Owner-friendly. Easy maintenance is a hallmark of the Phoenix's field proven design. Finished compost is removed just once a year.

Frost-safe. Freezing does not injure the composting process. In cold weather, use can continue at a lower rate. Composting resumes when the system warms up.

Energy efficient. A 12-volt-dc, 5-watt fan is the only electrical load in residential units.

Chemical-free. Requires only an organic bulking agent such as wood shavings. *No chemicals!* Composting uses a wide variety of natural organisms to biochemically decompose wastes.

Clog-proof. Rubber balls, apples, and other items that stop-up conventional flush toilets won't clog the foot-wide toilet chutes and food waste inlet chutes that connect to the Phoenix composting tank.

Pollution-free. Wastes are contained in the Phoenix. A long, uniform, retention time ensures a stable, biologically benign end product, reduced 80-90 percent in volume, that can be transported easily or disposed of on-site.

Residential Phoenixes

Phoenix residential packages contain all of the components necessary for installation except the wood shavings starter bed for the tank, and the 4-inch (100mm) rigid vent pipe. Every package has a Phoenix tank, one toilet with three feet (910mm) of chute, the ventilation system, a manual liquid respray system, a compost bin, rake, and installation and operating instructions.

Capacity. Capacities range from two to eight persons.

The capacity of the Phoenix system greatly depends upon the temperature of the compost pile. The rate of composting is significantly influenced by temperature. Warm tanks have a higher capacity than cold tanks.

Our capacity ratings assume a minimum tank room temperature of 65°F (18°C). Below 55°F (13°C), composting is very slow.

The **R-199** can be used continuously by two persons.

The **R-200** accommodates four full-time users.

The **R-201** accommodates eight full-time users.

Models R-199 and R-200 can be upgraded by adding a midsection.

Peak use. The Phoenix's large volume accommodates peak use well in excess of its long term rating, an important advantage in seasonal situations such as family reunions. The annual average use should not exceed the rating, but very heavy use over relatively short periods is handled easily.

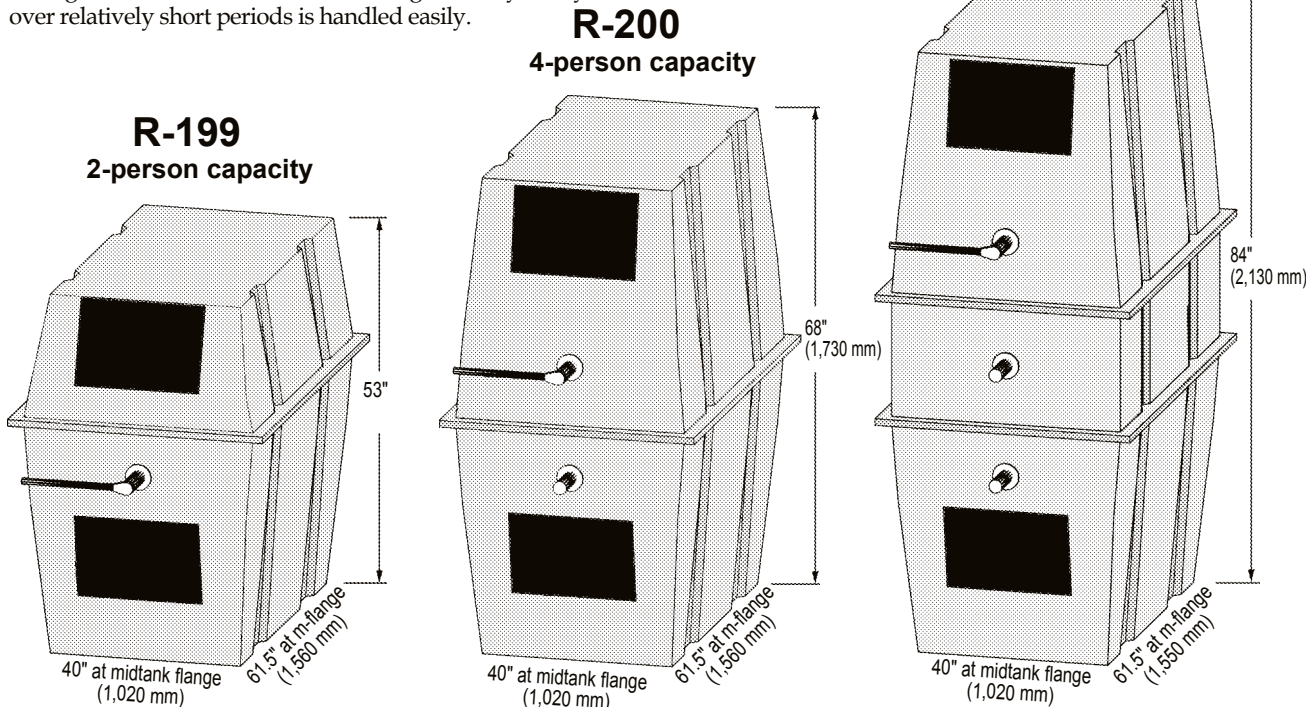

Graywater Treatment Options

A variety of options exist for treating graywater. Treatment systems that utilize natural biological processes require less energy, and are simpler and more reliable.

Health department approval. Graywater disposal systems usually require local health department approval prior to installation.

Conventional septic system/leach field. Because of graywater's lower flow volume, reduced oxygen demand, and lower suspended solids, the size of the septic tank and field can be reduced significantly. Alternatives to the septic tank, such as a roughing filter or forced aeration system, can enhance treatment before infiltration.

Leach water can be used to irrigate nonfood plants.

Constructed wetland. A diverse collection of aquatic plants is grown in a layer of gravel in a lined shallow trench. The root zone of these plants provides an aerobic environment for bacterial treatment of the flowing graywater. Treated water infiltrates the soil from an unlined portion of the trench. Nutrients can be recovered through biomass removal.

Aerobic infiltration bed. A coarse organic cover isolates the treatment area while allowing air exchange and providing a large surface area for biological activity and freeze protection. Increased longevity and significant nutrient recovery can be effected by alternating between two beds. In cold climates, the treatment can occur within a greenhouse.

Surface irrigation. Graywater can be spray irrigated on non-food plants. Treatment occurs in the biologically rich topsoil layer. Nutrients are recovered in the biomass.

The Toughest Composting Tank

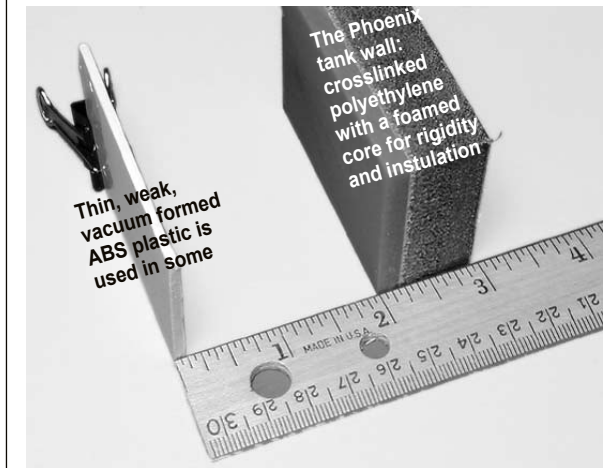

ACS fabricates the Phoenix from rotationally molded, crosslinked polyethylene, a tough, environmentally benign plastic that is highly resistant to corrosion and does not become brittle at low temperatures. Polyethylene can be recycled easily (many of our buildings use a decking material that contains recycled polyethylene). Fittings, fasteners, and other components are made from stainless steel, fiberglass, and other corrosion resistant materials.

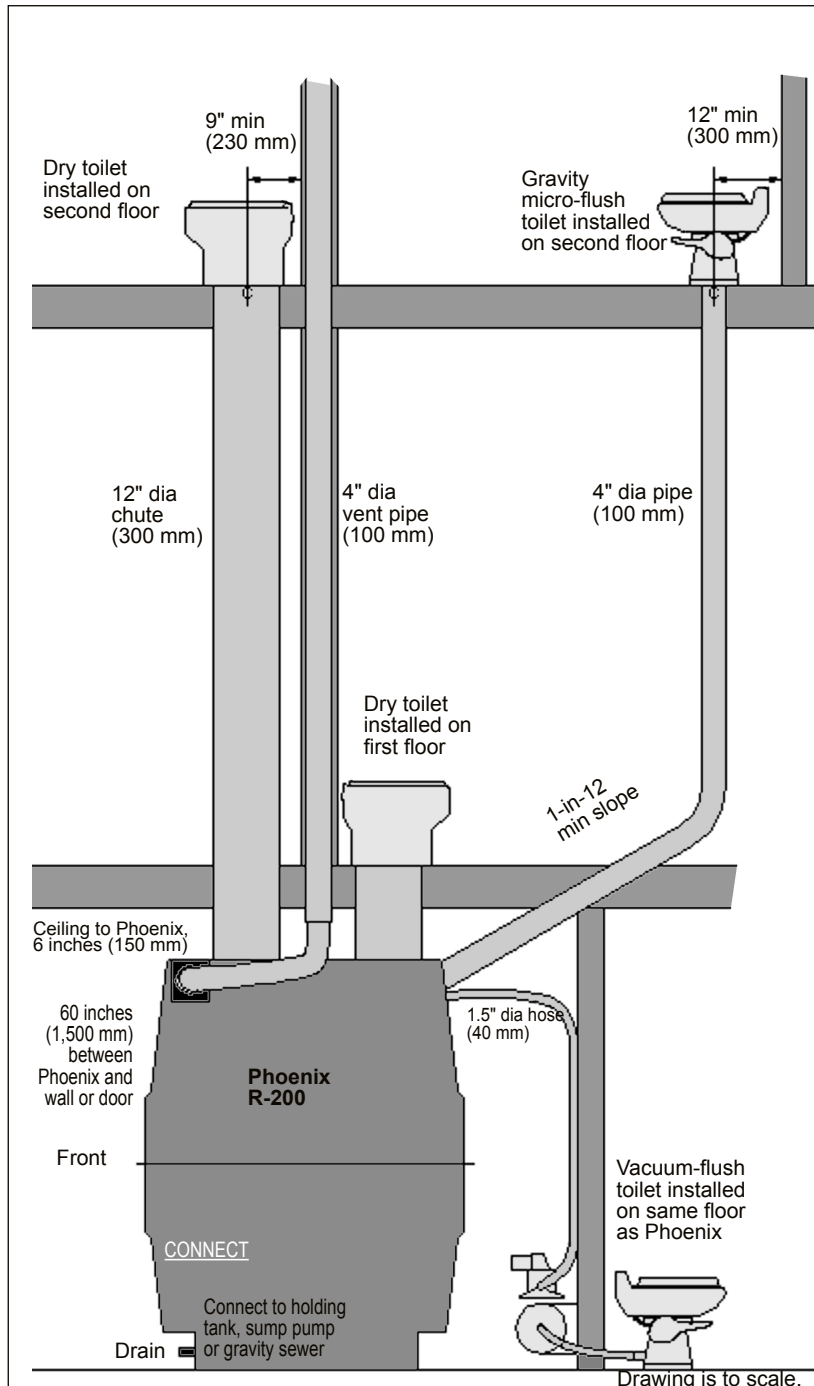

Installation Considerations

The area in which the Phoenix is located should be at least 43 inches (1,090 mm) wide. Five feet (1,500 mm) of clear space in front of the Phoenix must be provided for maintenance. This area should also be at least 6 inches (150 mm) taller than the tank. The surface supporting the Phoenix should be smooth, flat, level and capable of supporting 4,000 pounds (1,800 kg).

All Phoenix models are 40 inches (1,020 mm) wide and 62 inches (1,575 mm) long. Model 199 is 53 inches (1,350 mm) tall; Model 200, 68 inches (1,730 mm); Model 201, 84 inches (2,130 mm). The unassembled Phoenix fits through an opening 35 inches (890 mm) wide, the opening width of a 36-inch (910 mm) door.

Dry toilets connect to the Phoenix with 12-inch (310 mm) diameter chutes that must be vertical (see drawing at left). One Phoenix tank can accommodate two dry toilets on the same floor if they are located back-to-back. The toilets can also be located several stories above the tank. The minimum clearance from the center of the toilet chute to the finished surface of the wall behind the toilet is 9 inches (230 mm).

Gravity micro-flush toilets provide an alternative for installations requiring a toilet not directly above the Phoenix. They connect via a 4-inch (100 mm) pipe and require a one-pint water flush. The maximum horizontal offset from the Phoenix

is 10 feet (3,000 mm). The minimum slope is one inch per foot.

Vacuum-flush toilets offer an alternative for installations requiring a toilet on the same floor as the Phoenix (see drawing at left). They connect via a 1.5-inch (38 mm) diameter hose, and require running water and 12 or 24-volt electricity.

Leachate decants through the Phoenix drain which must be connected to a holding tank, sump pump or gravity sewer. Micro and vacuum-flush toilets increase the amount of liquid end product in the Phoenix.

The ventilation fan mounts on either side of the Phoenix. A short length of four-inch flexible hose connects the fan to 4-inch (100 mm) rigid pipe for exiting the roof. Avoid sharp turns and long horizontal runs. The flashing accommodates roof pitches from flat to 12/12. In cold climates, insulate the vent pipe to reduce frost accumulation and condensation. With high snow loads, the vent should exit near the roof ridge.

Electricity is required for the Phoenix's 12-volt-d.c., 5-watt ventilation fan. We provide a 12-volt-d.c. power supply for utility connected homes. An optional uninterruptible supply for areas with frequent electrical outages is available. An energy saving, electronic fan speed controller, available as an option, helps conserve energy in off-grid systems.

Seven Key Questions for Choosing the Right Composting Toilet for You

Composting is a familiar process to many rural and suburban residents. Organic materials, such as leaves, lawn clippings and food waste, are placed in a pile or enclosure. Over time, in the presence of oxygen, heat, and moisture, biochemical processes convert the waste to stabilized compost, which resembles rich, dark, potting soil. Pathogens are nearly eliminated and the volume of the organic material is reduced by 90 percent or more.

The same biochemical processes are employed by composting toilets to treat human waste. A composting toilet is a system that provides an environment for aerobic (in the presence of oxygen) decomposition. It is a miniature, on-site sewage treatment plant.

Not all composting toilets are created equal. They vary in size, materials, features, effectiveness, maintenance, energy requirements and safety. In choosing a composting system it is useful to consider the following questions:-

1. What are the durability, suitability and longevity of the materials used in manufacturing?
2. Does the size and shape of the composting vessel make sense?
3. Does compost removal require a pumper truck or climbing into the tank?
4. Can you remove compost without also removing fresh waste?
5. What are the energy and ventilation requirements?
6. What are the long term operating costs?
7. Would you personally be willing to perform the required maintenance?

The Phoenix Composting Toilet is a large and very rugged composting system that provides for the safe and effective stabilization of human waste on site. The insulated tank, efficient ventilation system and automatic controls assure the lowest possible heat and electrical requirements; most often these requirements can be met with solar energy. The Phoenix's built-in rotating tines and vertical design assure higher quality compost and easier, safer maintenance.

Rugged & Leakproof — Reliable Operation for a Lifetime

Fabricated from rotationally molded solid and foamed **crosslinked and linear polyethylene**.

A 5-watt, 12-volt d.c. **ventilation fan** moves oxygen through the compost and odors out the vent pipe.

Continuous air baffles along the tank sides facilitate **aeration** of the compost pile without interfering with compost movement.

Air enters the Phoenix through a **screened inlet**. A **sealed path** for ventilation air, and a large contact area, increase ventilation efficiency and allow supplemental heating.

Finished compost is **removed easily** through the **lower access door** from the entire bottom of the Phoenix.

Liquid is separated from the solids by a **screened baffle** and resprayed, or drained, from the Phoenix. The drain connection can be made from either side.

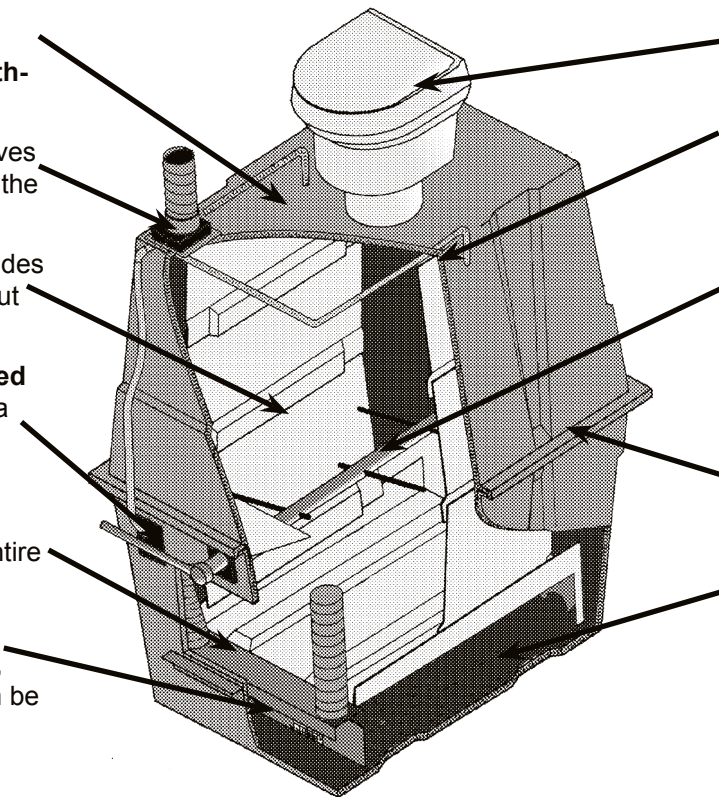

Durable **polyethylene and ABS plastic** toilets.

Accumulated liquid and/or fresh water is **sprayed** on top of the compost pile to **maintain moisture** and to inoculate the pile with compost-friendly micro-organisms.

Rotating tines control the downward movement of the material in the compost pile. The Phoenix Model 201 has three tine shafts, each above the other. The Model 200 (left) has two shafts (for clarity, only one tine shaft is shown in this illustration); the R-199 Cabin model, one.

A **gasket and interlocking flange** produce a **leakproof joint** with only a few bolts and no caulking.

A **permanent medium** provides **secondary liquid treatment** beneath the sloped bottom baffle. Air travels over the entire surface of the liquid to increase evaporation and aerobic conditions.

Phoenix Dimensions & Clearances

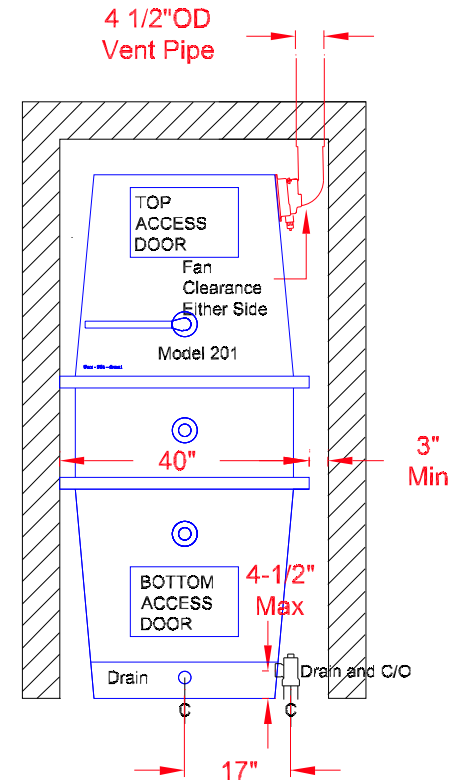
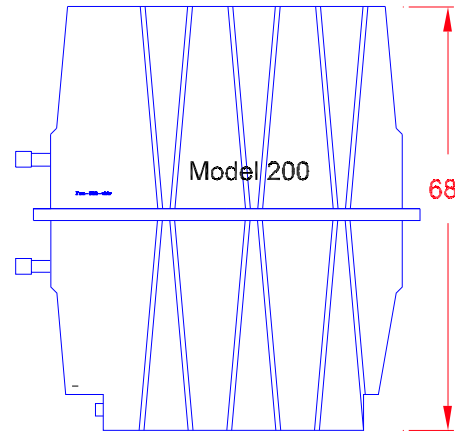
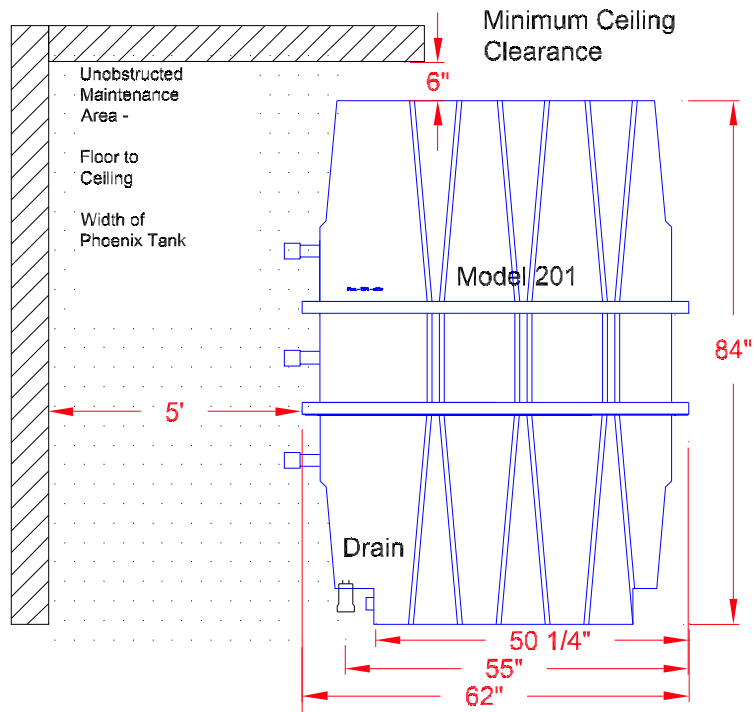
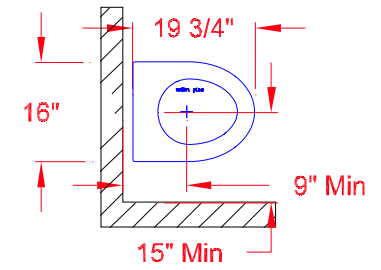
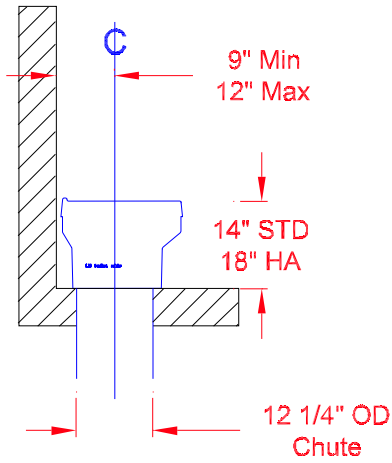
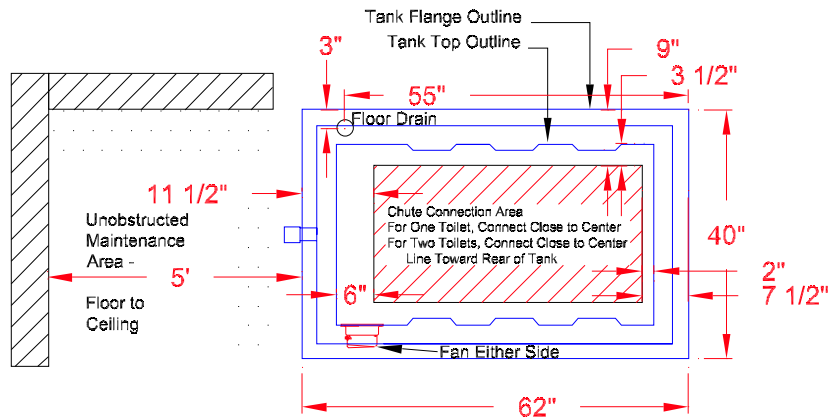

Phoenix Dimensions and Clearances

Available as Autocad .dwg file